

Membrane Pumps  
Solids Handling Pumps  
High Pressure Pumps  
Marine Pumps

# ABEL HP/HPT

High Pressure Pumps  
for Cleaning and Process Applications

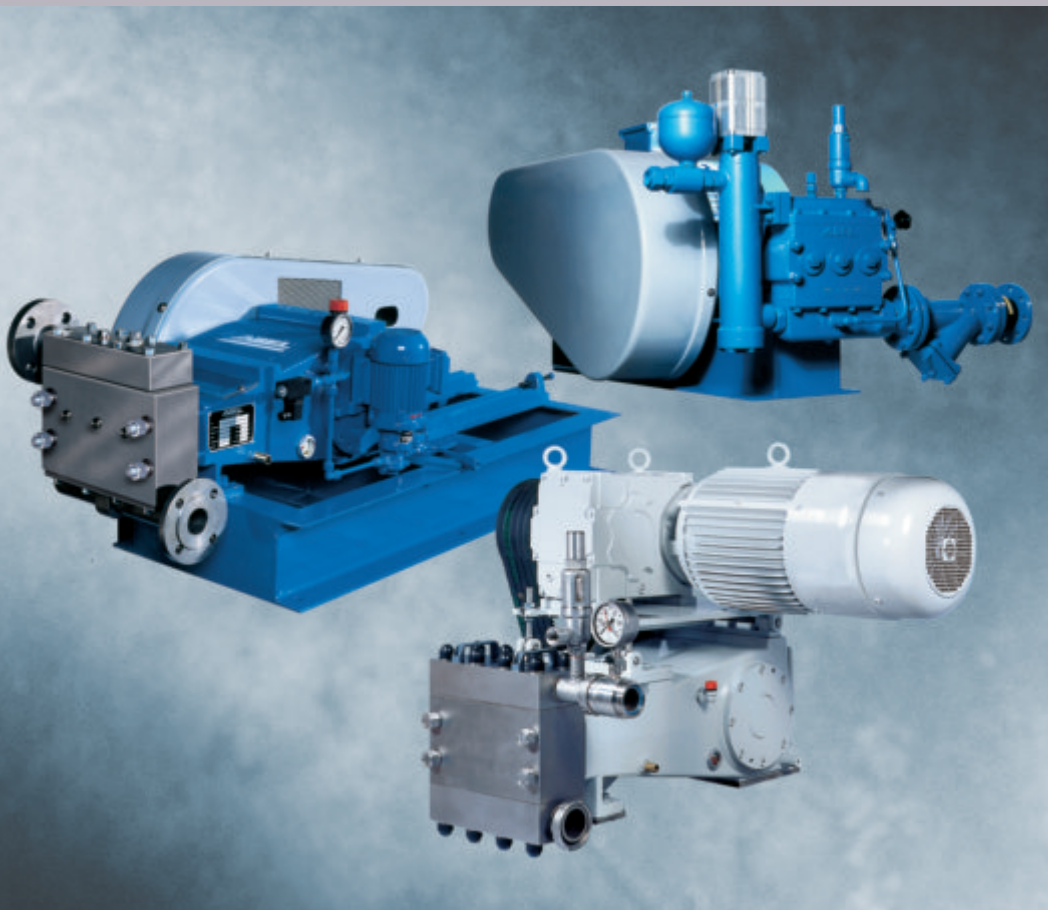

**Optimal operational safety**

**ABEL**<sup>®</sup>  
Pump Technology

# ABEL HP/HPT High Pressure Pumps

## Capacity range up to 52 m<sup>3</sup>/h, up to 25.0 MPa

### Purpose-built design

Just right  
for specific  
applications

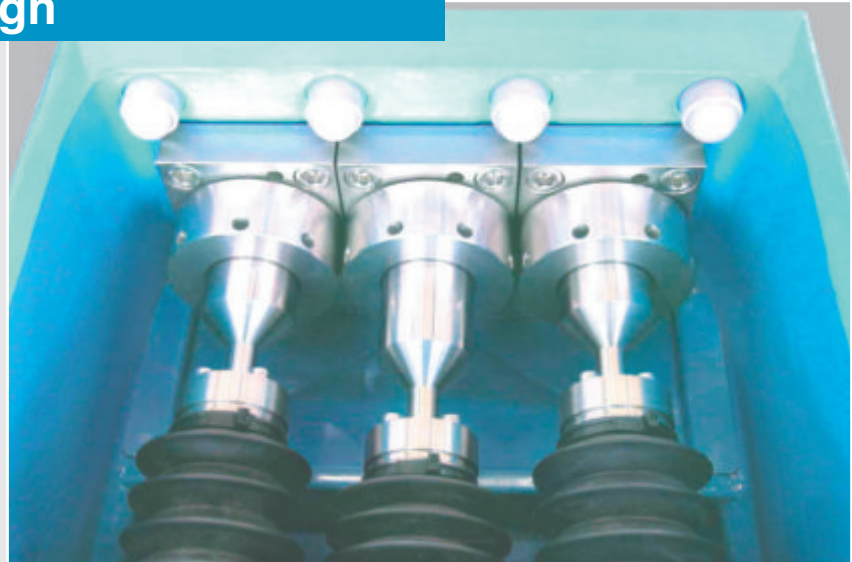

#### Areas of application

Cleaning of:

- Filter cloths
- Containers
- Apparatus
- Pipelines

#### Charging/feeding of:

- Reverse osmosis
- Boilers
- Reactors
- Other apparatus

In high-pressure cleaning and process technology ABEL high-pressure pumps prove successful during heavy-duty continuous operation:

A large number of satisfied customers is proof of the long lifetime and easy maintenance of our pumps, for example, in

- The water and wastewater industry
- The chemical industry
- Processing
- The pharmaceutical industry
- The food industry

The design is closely oriented on the requirements of the respective process and therefore enables the trouble-free integration of the pump at different plant interfaces. Less components enable a sound price-performance ratio, operational reliability and a high level of operational safety.

ABEL high-pressure pumps are self-priming, single-acting plunger pumps with 3 or 5 cylinders. Large valve cross-sections ensure uniform, low pulsation running.

The slow and very smooth running crank drive is lubricated by a splash oil system. Oil deflector plates ensure optimal lubrication of the important bearing points, even at particularly low speeds.

The bellows seal of the crosshead offers an optimal protection against the penetration of dust into the crank housing.

The plungers are available in high-quality stainless steels, hardened, chromium oxide coated or made of solid ceramics.



**Pumps of HP series are available with ATEX certification.**



### HP Selection Chart

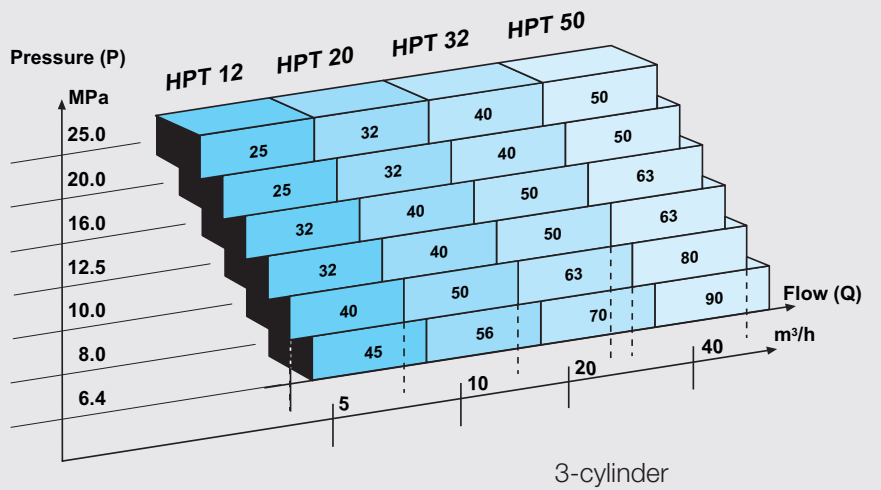
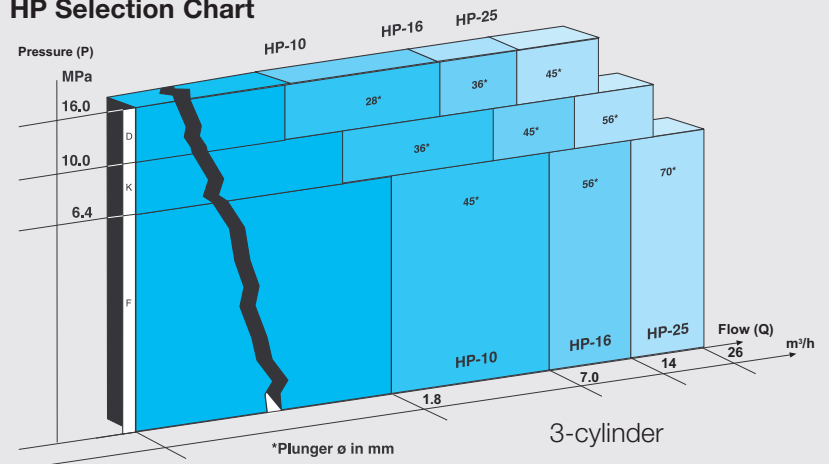

## Optimum Design

Strong  
and tough,  
to match  
the medium

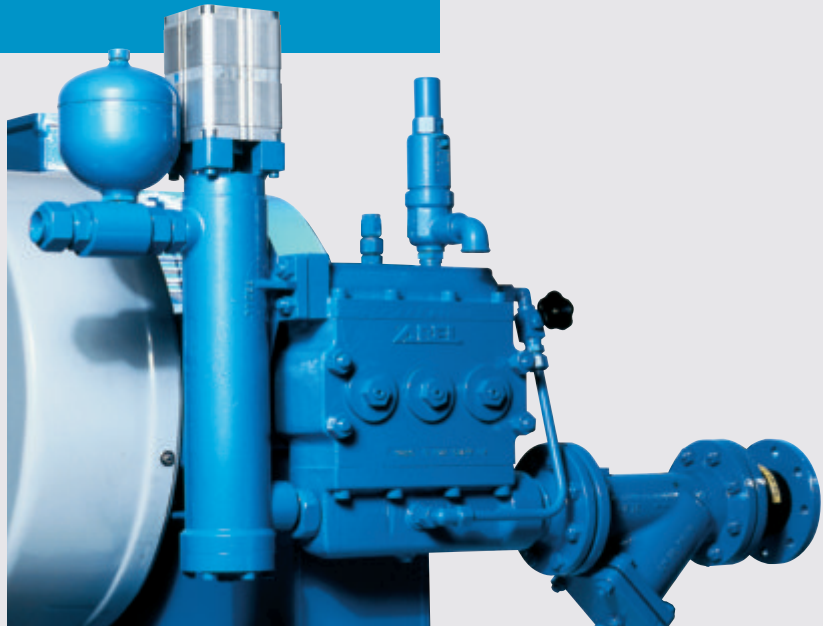

### Optional accessories

- Discharge side safety valve
- Pulsation dampener
- Suction/discharge side pressure gauges
- Shock absorbing components
- Sound control cabins and many others

Your product determines the housing material: nodular cast iron and stainless steel casting are also available as well as special bronzes.

Depending on application and pressure range, forged materials are used.

Adapted to the pumping media:

- Clean liquids
- Shear-sensitive and dwell-critical fluids

plate type, cone and ball valves are available

When intermittent operation is required, the pneumatically operated ABEL bypass valve ensures trouble-free interruption of the flow. Hydraulically operated bypass valves may also be used.

Different solutions matched with the product ensure the plunger sealing!

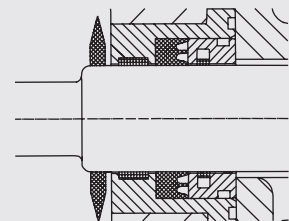

The automatic grooved ring as standard plunger seal for clean media is practically maintenance-free.

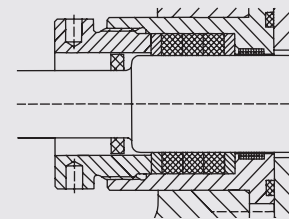

Gland packings in blocked or rinsed design for abrasive media.

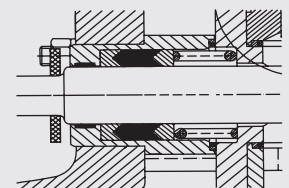

Chevron-type seals for food applications.

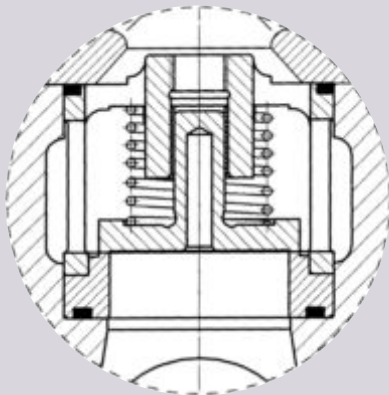
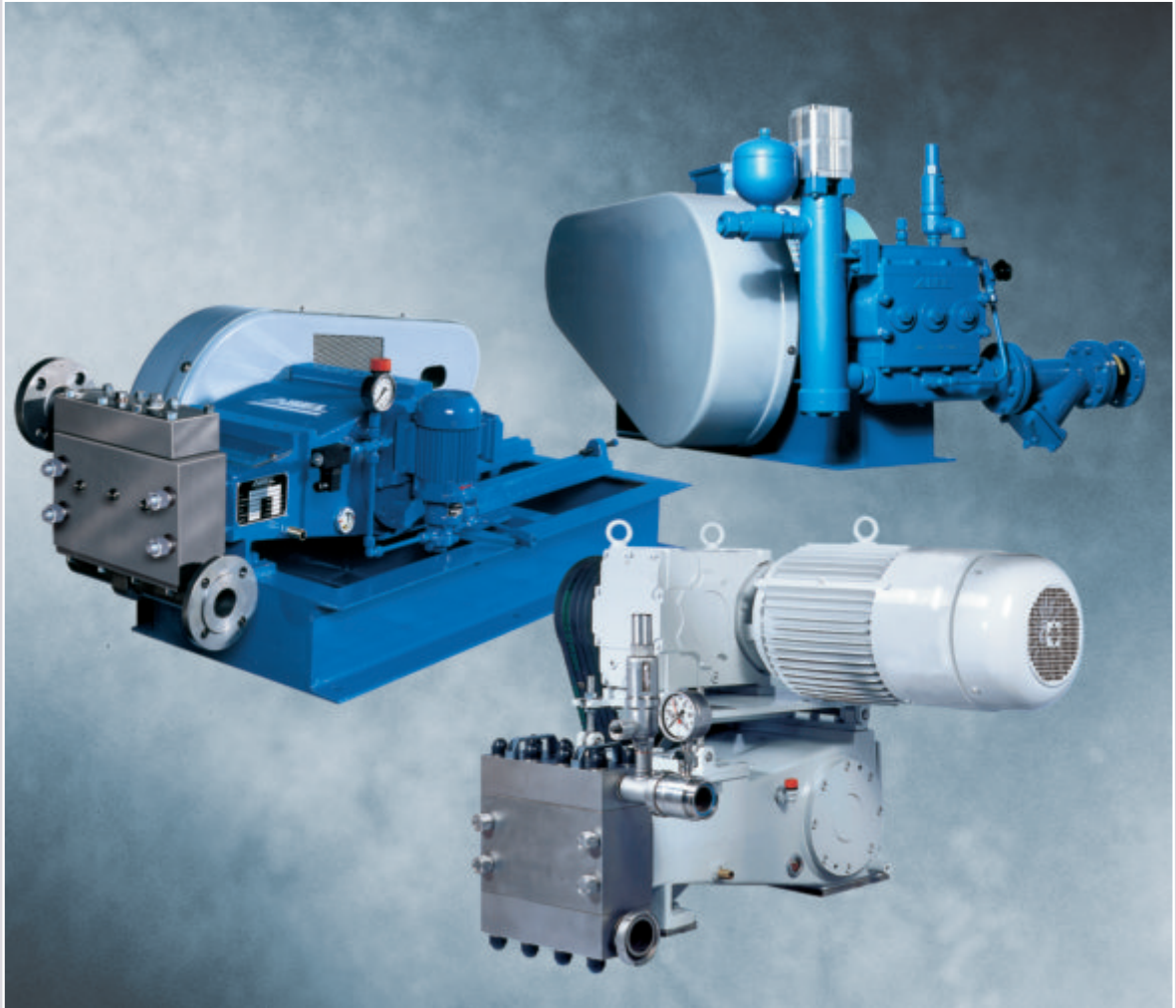
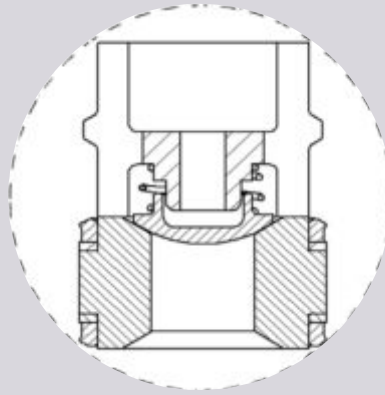
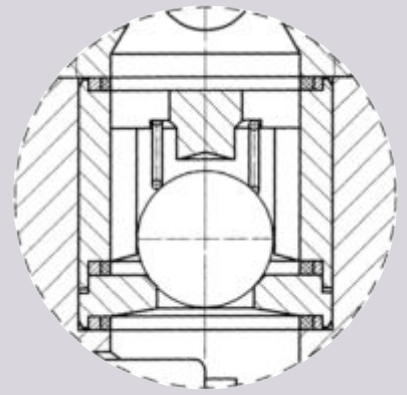

Plate valve



Spherical cone valve



Ball valve