

# POLIX

ŽIRI

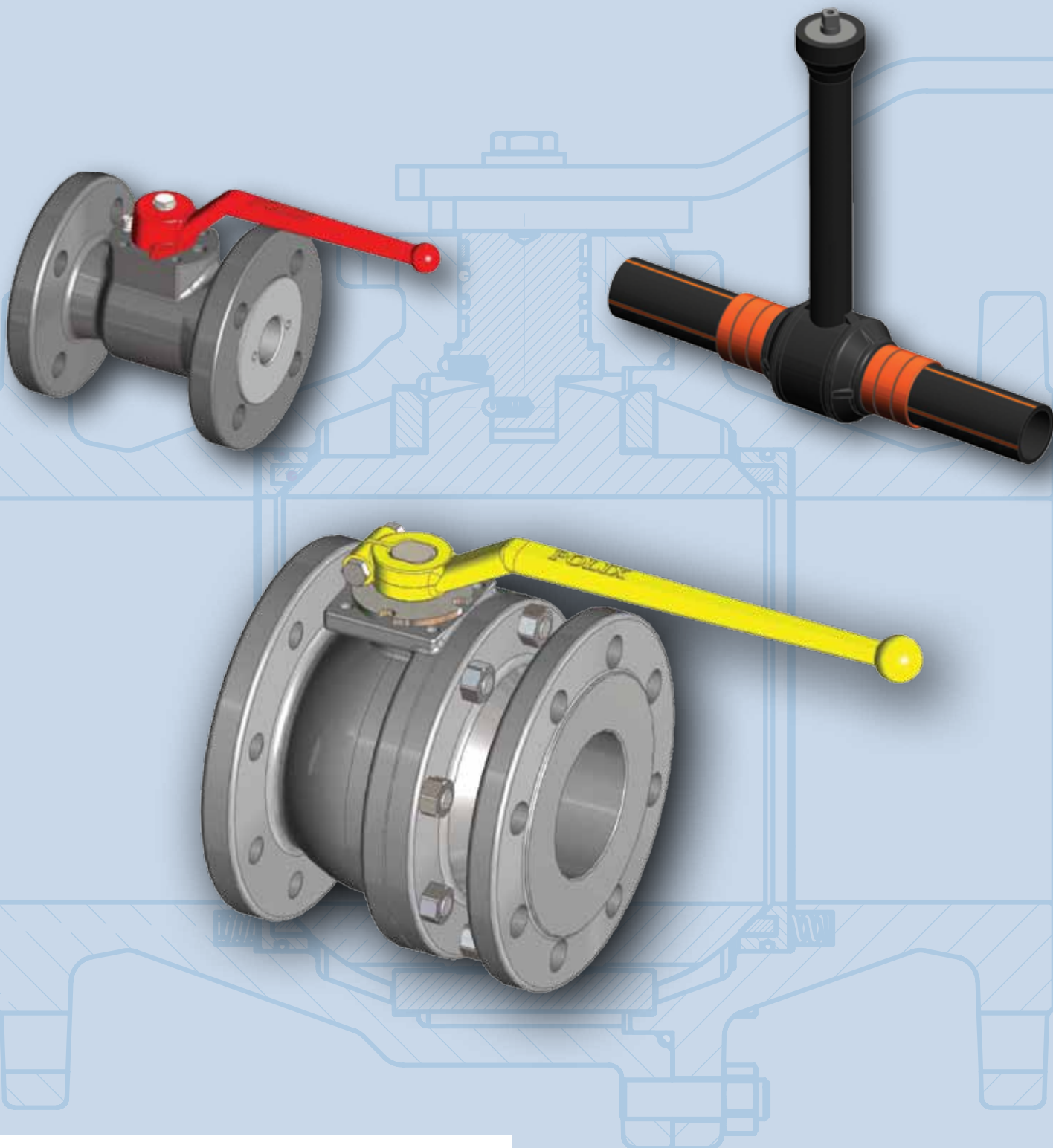

[www.rusimpsnab.ru](http://www.rusimpsnab.ru)

## О компании

История компании POLIX из города Жири была начата в 1965г. На протяжении десятилетий небольшая производственная компания превратилась в международную компанию, которая производит шаровые краны под собственным брендом POLIX с помощью инновационных подходов, основанных на внутренних знаниях и технологий.

Мы экспортируем и продаем более чем в 40 стран мира, определены мы как одни из самых наиболее важных компаний с промышленной арматурой на рынке DIN стандарта.

В результате напряженной работы и традиции мы получили сертификаты и знак качества, которые доказывают что наша арматура производится в соответствии с мировыми стандартами. Мы имеем сертификат DVGW, с которыми мы гарантируем нашим клиентам высокое качество установки в области водоснабжения и газопроводов. К постоянному совершенствованию технической и технологической области, мы приобрели февраля 1995 сертификат ISO 9001-2000. В 2010 году мы получили директиву о выявлении соответствия Европейская директива оборудования под давлением 97/23/ЕС по модулю X (полный контроль качества).



## BALL VALVES – GAS

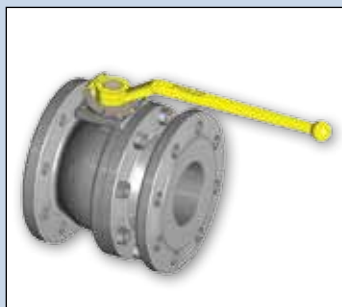

**KPN-G** PN16, PN40  
**Body:** Ductile Iron – GGG40  
**Ball:** Stainless Steel – X 5 Cr Ni 18 10  
**Stem:** Stainless Steel – X 20 Cr 13  
**Seats:** PTFE  
**O-Ring:** Viton  
**Handle:** Al Si 8  
**Size:** DN15–DN250



**KPV-G, FLANGED** PN16, PN40  
**Body:** Carbon Steel – St 52-3  
**Ball:** Stainless Steel – X 5 Cr Ni 18 10  
**Stem:** Stainless Steel – X 20 Cr 13  
**Seats:** PTFE  
**O-Ring:** Viton  
**Handle:** Al Si 8  
**Size:** DN25–DN250

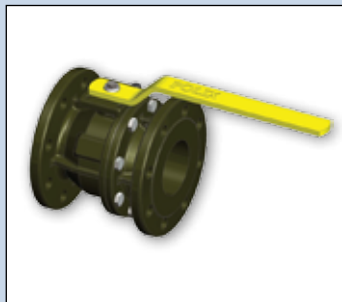

**KPC-G** PN16  
**Body:** Ductile Iron – GGG40  
**Ball:** Brass – MS 58 – Chrome plated  
**Stem:** Stainless Steel – X 20 Cr 13  
**Seats:** PTFE  
**O-Ring:** Viton  
**Handle:** Iron – St 37-2  
**Size:** DN25–DN200

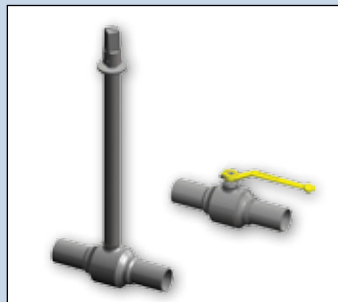

**KPV-G, WELDED** PN40  
**Body:** Carbon Steel – St 52-3  
**Ball:** Stainless Steel – X 5 Cr Ni 18 10  
**Stem:** Stainless Steel – X 20 Cr 13  
**Seats:** PTFE  
**O-Ring:** Viton  
**Handle:** Al Si 8  
**Size:** DN25–DN250



**KPA-G** PN16, PN40  
**Body:** Carbon Steel – St 52-3  
**Ball:** Stainless Steel – X 5 Cr Ni 18 10  
**Stem:** Stainless Steel – X 20 Cr 13  
**Seats:** PTFE  
**O-Ring:** Viton  
**Handle:** Iron – St 37-2  
**Size:** DN15–DN200

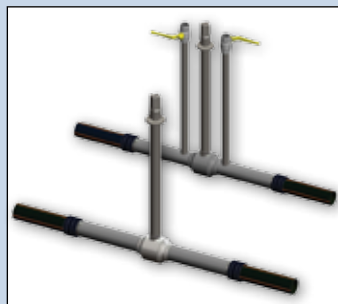

**KPV-G** PN10  
**Body:** Carbon Steel – St 52-3  
**Ball:** Stainless Steel – X 5 Cr Ni 18 10  
**Stem:** Stainless Steel – X 20 Cr 13  
**Seats:** PTFE  
**O-Ring:** Viton  
**Stem extension:** Carbon Steel  
**Transitional piece:** Steel-Polyethylene – PE  
**Size:** DN32–DN225



**KPF-G** Ansi150, Ansi300  
**Body:** Carbon Steel – St 52-3  
**Ball:** Stainless Steel – X 5 Cr Ni 18 10  
**Stem:** Stainless Steel – X 20 Cr 13  
**Seats:** PTFE  
**O-Ring:** Viton  
**Handle:** Iron – St 37-2  
**Size:** DN25–DN150



**KPV-G** PN10  
**Body:** Carbon Steel – St 25-3  
**Ball:** Stainless Steel – X 5 Cr Ni 18 10  
**Seats:** PTFE  
**Stem:** Stainless Steel – X 20 Cr 13  
**O-Ring:** Viton (FPM)  
**Isolation:** Polyurethane Anticorrosive protection  
**Embrace ring:** Seamless pipe – Plastic Cover  
**Transitional piece:** Polyethylene – PE  
**Size:** DN32–DN225

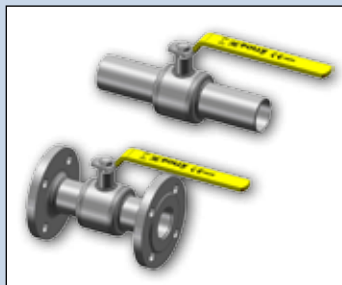

**KPT-G** PN16  
**WELDED OR FLANGED FULL**  
**Body:** Carbon Steel – St 52-3  
**Ball:** Stainless Steel – X 5 Cr Ni 18 10  
**Stem:** Stainless Steel – X 20 Cr 13  
**Seats:** PTFE  
**O-Ring:** Viton  
**Handle:** Carbon Steel – St 37-2 Galvanised  
**Size:** DN15–DN200

## BALL VALVES

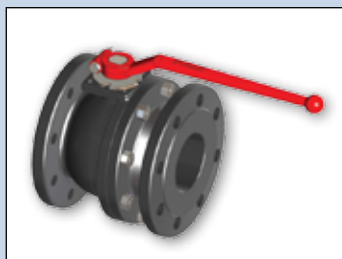

**KPN** PN16, PN40  
**Body:** Ductile Iron – GGG40  
**Ball:** Stainless Steel – X 5 Cr Ni 18 10  
**Stem:** Stainless Steel – X 20 Cr 13  
**Seats:** PTFE  
**O-Ring:** NBR  
           EPDM  
           PTFE  
**Handle:** Al Si 8  
**Size:** DN15–DN250

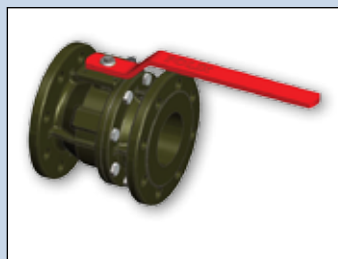

**KPC** PN6, PN16, PN40  
**Body:** Ductile Iron – GGG40  
**Ball:** Brass – MS 58 – Chrome plated  
**Stem:** Brass – MS 58  
**Seats:** PTFE  
**O-Ring:** NBR  
           EPDM  
           PTFE  
**Handle:** Iron – St 37-3  
**Size:** DN25–DN200

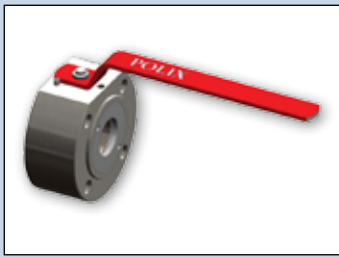

**KPA** PN16, PN40  
**Body:** Carbon Steel – St 52-3  
**Ball:** Stainless Steel – X 5 Cr Ni 18 10  
**Stem:** Stainless Steel – X 20 Cr 13  
**Seats:** PTFE  
**O-Ring:** PTFE  
**Handle:** Iron – St 37-3  
**Size:** DN15–DN200

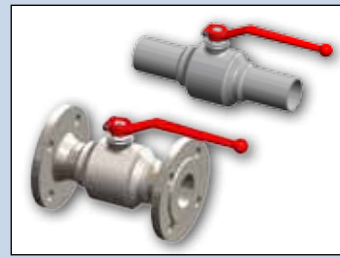

**KPV** PN40  
**Body:** Carbon Steel – St 52-3  
**Ball:** Stainless Steel – X 5 Cr Ni 18 10  
**Stem:** Stainless Steel – X 20 Cr 13  
**Seats:** PTFE  
**O-Ring:** PTFE  
**Handle:** Al Si 8  
**Size:** DN65–DN250

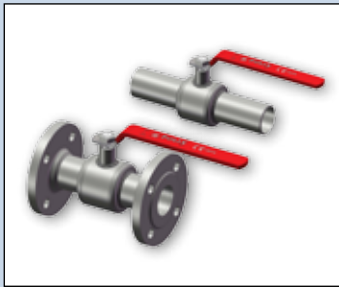

**KPT** PN16, PN25, PN40  
**WELDED OR FLANGED FULL OR REDUCED BORE**  
**Body:** Carbon Steel – St 52-3  
**Ball:** Stainless Steel – X 5 Cr Ni 18 10  
**Stem:** Stainless Steel – X 20 Cr 13  
**Seats:** PTFE  
**O-Ring:** PTFE  
**Handle:** Carbon Steel – St 37-2 Galvanised  
**Size:** DN15–DN250 (full bore)  
 DN20–DN250 (reduced bore)

## BALL VALVES – ABRASIVE MEDIUMS

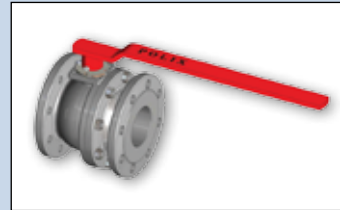

**KPN** PN16  
**Body:** Ductile Iron – GGG40  
**Ball:** Stainless Steel – X 5 Cr Ni 18 10  
**Stem:** Stainless Steel – X 20 Cr 13  
**Seats:** Alloy – CuSn5Pb5ZN5  
**O-Ring:** NBR  
**Handle:** St 37-2  
**Size:** DN25–DN150

## GATE VALVES



**RESILIENT SEATED** PN10, PN16  
**FLAT F4 & OVAL BODY F5**  
**Body:** Ductile Iron – GGG50  
**Wedge:** Ductile Iron – GGG50 with NBR coating  
**Stem nut:** Brass  
**Stem:** Stainless Steel – A304  
**Bonnet:** Ductile Iron – GGG50  
**Handwheel:** Ductile Iron – GGG50  
**Dust ring:** NBR  
**Sealing:** PTFE  
**O-Ring:** NBR  
**Size:** DN40–DN300



**METAL SEATED** PN16  
**Body:** Cast Iron – GG25  
**Wedge:** Cast Iron – GG25  
**Body seat ring & disc seat ring:** Brass  
**Stem nut:** Brass  
**Stem:** Stainless Steel – A304  
**Bonnet:** Cast Iron – GG25  
**O-Ring:** EPDM  
**Packing:** Graphite  
**Handwheel:** Cast Iron – GG25  
**Size:** DN40–DN300

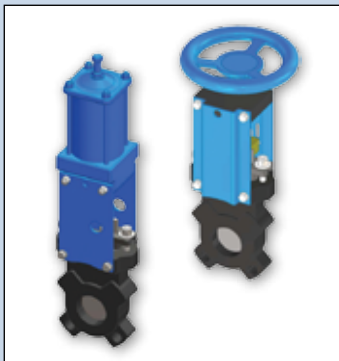

**KNIFE GATE** PN10  
**Body:** Cast Iron – GG25  
**Gate:** Stainless Steel – A304  
**Packing:** PTFE impregnated Syntex Fibre  
**Gland:** Ductile Iron (Powder Coated)  
**Fasteners (gland):** Carbon Steel (Plated)  
**Side Plate:** Carbon Steel (Powder Coated)  
**Fasteners (for side plate):** Carbon Steel (Plated)  
**Stem:** Stainless Steel – A304  
**Hand Wheel:** Steel (Powder Coated)  
**Actuator:** Frp Tube  
**Seat:** EPDM  
**Size:** DN50–DN300

## GLOBE VALVES



**STAINLESS STEEL TRIM** PN16  
**Body:** Cast Iron – GG25  
**Seat Ring:** Stainless Steel – A304  
**Disc:** Stainless Steel – A304  
**Packing:** Graphite  
**Bonnet Gasket:** Graphite  
**Bonnet:** Cast Iron – GG25  
**Stem:** Stainless Steel – A304  
**Handwheel:** Steel  
**Size:** DN15–DN250



**BRASS TRIM** PN6, PN16  
**Body:** Cast Iron – GG25  
**Seat Ring:** Brass  
**Disc:** Cast Iron – GG25, Brass gasket  
**Packing:** Graphite  
**Bonnet Gasket:** Graphite  
**Bonnet:** Cast Iron – GG25  
**Stem:** Stainless Steel – A410  
**Handwheel:** Cast Iron – GG25  
**Size:** DN15–DN200

## BUTTERFLY VALVE



**WAFER CI/DI** PN16  
**Body:** Cast Iron – GG25  
**Disc:** Ductile Iron – GGG50  
**Stem:** Stainless Steel – A304  
**Seat:** EPDM  
**Bushing:** PTFE  
**O-Ring:** EPDM  
**Size:** DN40–DN300



**WAFER DI/SS** PN16  
**Body:** Ductile Iron – GGG50  
**Disc:** Stainless Steel – A316  
**Stem:** Stainless Steel – A304  
**Seat:** EPDM or NBR  
**Bushing:** PTFE  
**O-Ring:** EPDM  
**Size:** DN40–DN300





### LUGGED

PN16

**Body:** Ductile Iron – GGG50  
**Disc:** Stainless Steel – A316  
**Stem:** Stainless Steel – A304  
**Seat:** EPDM or NBR  
**Bushing:** PTFE  
**O-Ring:** EPDM  
**Size:** DN40–DN300

## CHECK VALVE



### SWING

PN6, PN16

**Body:** Cast Iron – GG25  
**Bonnet:** Cast Iron – GG25  
**Hanger Pin:** Brass  
**Hanger:** Ductile Iron – GGG40  
**Disc:** Cast Iron – GG25  
**Disc Ring:** EPDM  
**Body Ring:** Brass  
**Size:** DN40–DN300



### WAFER DOUBLE DISC

PN16

**Body:** Cast Iron – GG25  
**Disc:** Stainless Steel – A304  
**Seat gasket:** EPDM  
**Axle:** Stainless Steel – A304  
**Spring:** Stainless Steel – A304  
**Seal:** EPDM  
**Size:** DN50–DN300



### SILENT

PN16

**Body:** Cast Iron – GG25  
**Guide:** Cast Iron – GG25  
**Guiding stem:** Cast Iron – GG25  
**Bushing:** Brass  
**Spring:** Stainless Steel – A304  
**Seal:** EPDM  
**Size:** DN50–DN300

### STRAINER FOR SILENT CHECK VALVE

**Body:** Galvanized Steel  
**Size:** DN50–DN300



### WAFER SWING

PN16

**Body:** Carbon Steel – A105 Galvanized  
**Disc:** Stainless Steel – A304  
**O-Ring:** NBR  
**Size:** DN40–DN200



### FLANGED

PN16

**Body:** Ductile Iron – GGG40  
**Ball:** Aluminium NBR wrapped (DN50 – DN150)  
 Steel NBR wrapped (DN200)  
**Bonnet:** Ductile Iron – GGG40  
**Washer:** Carbon Steel Zinc plated  
**Bolt:** Carbon Steel Zinc plated  
**O-Ring:** NBR  
**Size:** DN50–DN200



### WAFER SPRING

PN40

**Body:** Stainless Steel – A316  
**Spring cover:** Stainless Steel – A316  
**Spring:** Stainless Steel – A316  
**Bolt:** Stainless Steel – A316  
**Disc:** Stainless Steel – A316  
**Size:** DN15 – DN100



### THREADED

PN16

**Body:** Ductile Iron – GGG40  
**Ball:** Aluminium NBR wrapped  
**Cover:** Ductile Iron – GGG40  
**Nut:** Carbon Steel Zinc plated  
**Bolt:** Carbon Steel Zinc plated  
**O-Ring:** NBR  
**Size:** 1"–3"

*\*Threaded according to BSP*

## RUBBER FLEXIBLE JOINT



### FLANGED

PN6, PN16

**Body:** EPDM  
**Wire:** Steel  
**Flange:** Carbon Steel  
**Size:** DN32–DN300

### THREADED

PN16

**Body:** EPDM  
**Union:** Galvanized Cast Iron – GGG25  
**Size:** 3/4"–3"

## DIRT STRAINER



### DIRT STRAINER

PN6, PN16

**Body:** Cast Iron – GG25  
**Bonnet:** Cast Iron – GG25  
**Bolt:** Galvanized Steel  
**Gasket:** Graphite Steel  
**Wire mesh:** Stainless Steel – A304  
**Plug:** Galvanized Steel  
**Size:** DN15–DN300

## NECK FLANGES



### NECK FLANGES

PN6, PN16, PN40

**Body:** Carbon Steel – C22.8  
**Size:** DN15–DN600

**DIN-DVGW-Baumusterprüfzertifikat**  
**DIN-DVGW type examination certificate**

NS-411801183

**Anwendungsbereich** Produkt der Gasversorgung  
**Art of application** products of gas supply

**Zertifizierter Hersteller** POLIMIX ZIRI s.p.a.  
**Manufacturer** Polimix s.p.a.,  
 Industriestraße 11, 50-2-4228 Zyrardow

**Produkt** gas fittings: shut-off valve for total gas distribution → PN 16 (4212)  
**Product** gas fittings: shut-off valve for total gas distribution → PN 16 (4212)

**Produktbeschreibung** Shut-off valve for gas equipment and gas distribution  
**Product description** Shut-off valve for gas equipment and gas distribution

**Modell** 8796-G\_PN 16 ZP  
**Model** 8796-G\_PN 16 ZP

**Prüfberichte** V4 A 1298-0228 vom 25.10.2008 (TSG)  
**Test reports** V4 A 1298-0228 vom 25.10.2008 (TSG)

**Prüfungsinstitut** DIN EN 12716 01-07-2005  
**Test institute** DIN EN 12716 01-07-2005

**Ausstellungs- / AZ** 01.11.2014 / 16-0384-DW  
**Date of expiry / 16 No.** 01.11.2014 / 16-0384-DW

**DIN-DVGW type examination certificate**  
**DIN-DVGW-Baumusterprüfzertifikat**

NS-411817408

**Field of Application** products of gas supply  
**Anwendungsbereich** Produkte der Gasversorgung

**Owner of Certificate** POLIMIX s.p.a.  
**Zertifizierter Hersteller** POLIMIX s.p.a.,  
 Industriestraße 11, 50-2-4228 Zyrardow

**Produkt** gas fittings: shut-off valve for total gas distribution → PN 16 (4212)  
**Product** gas fittings: shut-off valve for total gas distribution → PN 16 (4212)

**Produktbeschreibung** Straight pattern ball valve  
**Product description** Straight pattern ball valve

**Modell** 8796-G\_PN 16 ZP  
**Model** 8796-G\_PN 16 ZP

**Prüfberichte** V4 A 1271-0271 vom 16.02.2011 (TSG)  
**Test reports** V4 A 1271-0271 vom 16.02.2011 (TSG)

**Prüfungsinstitut** DIN EN 12716 01-07-2005  
**Test institute** DIN EN 12716 01-07-2005

**Ausstellungs- / AZ** 01.11.2014 / 16-0384-DW  
**Date of expiry / 16 No.** 01.11.2014 / 16-0384-DW

**DIN-DVGW-Baumusterprüfzertifikat**  
**DIN-DVGW type examination certificate**

NS-411817408

**Anwendungsbereich** Produkt der Gasversorgung  
**Art of application** Product of gas supply

**Zertifizierter Hersteller** POLIMIX s.p.a.  
**Manufacturer** Polimix s.p.a.,  
 Industriestraße 11, 50-2-4228 Zyrardow

**Produkt** gas fittings: shut-off valve for total gas distribution → PN 16 (4212)  
**Product** gas fittings: shut-off valve for total gas distribution → PN 16 (4212)

**Produktbeschreibung** Hergestellt in Deutschland  
**Product description** Manufactured in Germany

**Modell** 8796-G\_PN 16 ZP  
**Model** 8796-G\_PN 16 ZP

**Prüfberichte** V4 A 1271-0271 vom 16.02.2011 (TSG)  
**Test reports** V4 A 1271-0271 vom 16.02.2011 (TSG)

**Prüfungsinstitut** DIN EN 12716 01-07-2005  
**Test institute** DIN EN 12716 01-07-2005

**Ausstellungs- / AZ** 01.11.2014 / 16-0384-DW  
**Date of expiry / 16 No.** 01.11.2014 / 16-0384-DW

**CE 0085**

**EG-Registrierbescheinigung**  
**EC registration certificate**

CE-0085B01

**Anwendungsbereich** EG-Gasgeräte (DIN EN 15713)  
**Art of application** EG-Gasgeräte (DIN EN 15713)

**Zertifizierter Hersteller** POLIMIX s.p.a.  
**Manufacturer** Polimix s.p.a.,  
 Industriestraße 11, 50-2-4228 Zyrardow

**Produkt** Gasgeräte: Kugelventil → PN 16 (4212)  
**Product** Gas equipment: Ball valve → PN 16 (4212)

**Produktbeschreibung** Abhängig vom Design  
**Product description** Depending on design

**Modell** 8796-G\_PN 16 ZP  
**Model** 8796-G\_PN 16 ZP

**Prüfberichte** DIN 12716/02 vom 26.03.2008 (DIN)  
**Test reports** DIN 12716/02 vom 26.03.2008 (DIN)

**Prüfungsinstitut** EG 01/03/05 A N 41 (26.03.1997)  
**Test institute** EG 01/03/05 A N 41 (26.03.1997)

**Ausstellungs- / AZ** 16.12.2011 / 01-1386-028  
**Date of expiry / 16 No.** 16.12.2011 / 01-1386-028

**CE 0085**

**EC type examination certificate**  
**EG-Baumusterprüfbescheinigung**

CE-0085B01

**Field of Application** EG-Gasgeräte (DIN EN 15713)  
**Anwendungsbereich** EG-Gasgeräte (DIN EN 15713)

**Owner of Certificate** POLIMIX s.p.a.  
**Zertifizierter Hersteller** POLIMIX s.p.a.,  
 Industriestraße 11, 50-2-4228 Zyrardow

**Produkt** gas fittings: shut-off valve for total gas distribution → PN 16 (4212)  
**Product** gas fittings: shut-off valve for total gas distribution → PN 16 (4212)

**Produktbeschreibung** Straight pattern ball valve  
**Product description** Straight pattern ball valve

**Modell** 8796-G\_PN 16 ZP  
**Model** 8796-G\_PN 16 ZP

**Countries of Destination** European Union, CH, IS, NO  
**Landes der Bestimmung** Europäische Union, CH, IS, NO

**Test Reports** V4 A 1271-0271 vom 16.02.2011 (TSG)  
**Prüfberichte** V4 A 1271-0271 vom 16.02.2011 (TSG)

**Test Basis** EG 01/03/05 A N 41 (26.03.1997)  
**Prüfungsinstitut** DIN EN 12716 01-07-2005

**File Number** 11-028-002  
**Ausstellungs-**

**BUREAU VERITAS**  
 Certification

**Certification**  
 awarded to  
**POLIMIX ZIRI d.o.o.**  
 Industrijska 4, 50200 Zyrardow

**ISO 9001:2008**

**Scope of scope**  
 DEVELOPMENT, PRODUCTION AND SALES OF POLYMER VALVE  
 SALES OF OTHER METALLIC PRODUCTS

**Product Approval No.** 0000000001  
**Issue date** 08/02/2011

**REGISTRIERUNG**  
**ZULASSUNG**

**ZULASSUNG**  
**CERTIFICATE OF QUALITY SYSTEM APPROVAL**  
 N° CE PED-4-POX 001-1511

**Produkt** Kugelventil → PN 16 (4212)  
**Product** Ball valve → PN 16 (4212)

**Prüfungsinstitut** DIN EN 12716 01-07-2005  
**Test institute** DIN EN 12716 01-07-2005

**AGA CERTIFIED PRODUCT**

**AGA**

**Certificate holder** POLIMIX EXPORT s.p.a.  
**Hersteller** POLIMIX EXPORT s.p.a.

**Art of application** Ball Valve  
**Produkt** Kugelventil → PN 16 (4212)

**Temperature Range** -20°C-40°C  
**Druck** 16bar

**Modell** 8796-G\_PN 16 ZP  
**Model** 8796-G\_PN 16 ZP

**Prüfungsinstitut** AGA 0017-2004  
**Test institute** AGA 0017-2004

**СИСТЕМА СЕРТИФИКАЦИИ ГОСТ Р**  
**ФЕДЕРАЛЬНОЕ АГЕНСТВО ПО ТЕХНИЧЕСКОМУ РЕГУЛИРОВАНИЮ И МЕТРОЛОГИИ**

**СЕРТИФИКАТ СООТВЕТСТВИЯ**  
 № РОСС RU.МНТ.80040

**ГОСТ Р 51627-2008**  
 Газовые краны

**СЕРТИФИКАЦИЯ**  
 № РОСС RU.МНТ.80040

**ГОСТ Р 51627-2008**  
 Газовые краны

**СИСТЕМА СЕРТИФИКАЦИИ ГОСТ Р**  
**ФЕДЕРАЛЬНОЕ АГЕНСТВО ПО ТЕХНИЧЕСКОМУ РЕГУЛИРОВАНИЮ И МЕТРОЛОГИИ**

**СЕРТИФИКАТ СООТВЕТСТВИЯ**  
 № РОСС RU.МНТ.80040

**ГОСТ Р 51627-2008**  
 Газовые краны

**СЕРТИФИКАЦИЯ**  
 № РОСС RU.МНТ.80040

**ГОСТ Р 51627-2008**  
 Газовые краны

**РАЗРЕШЕНИЕ**  
 № РОСС RU.МНТ.80040

**РАЗРЕШЕНИЕ**  
 № РОСС RU.МНТ.80040

**ГОСТ Р 51627-2008**  
 Газовые краны



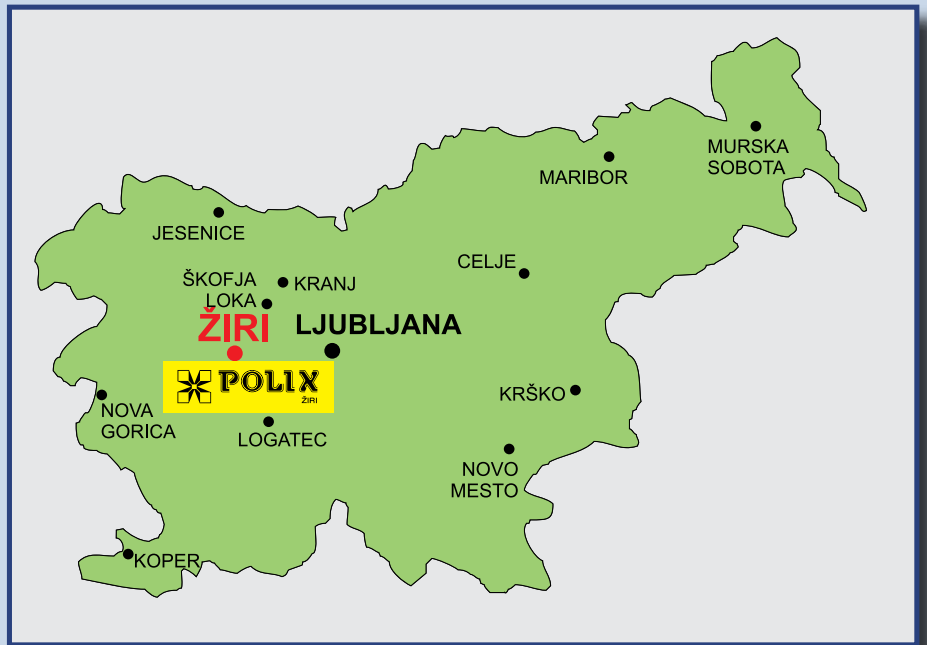

ООО "РусИмпортСнаб"  
Представитель POLIX в Российской Федерации  
115093, Россия, г. Москва. Б.Серпуховская, д.44, оф.19  
Тел. +7 (495) 972-85-65  
[polix@rusimpsnab.ru](mailto:polix@rusimpsnab.ru)  
[www.rusimpsnab.ru](http://www.rusimpsnab.ru)